

Load Chain Maker Developed New Age Highest Grade



Lever Hoist YA

**Strongest Load chain ever
than before ☺ B39 VH**

YA is equipped with new developed
load chain Grade +V (plus V) 105kgf/mm².

Improved shape of lever

Round shape lever handle
brings easy operation.

Safety factor 5 times

Load chain, hooks, braking parts
have 5 times safety factor.
(0.8t~1.6t)

Round-shape lever



Patent and copyright registered.

Model	Safety working load	Load chain Min. breaking load	Safety factor
YA-80	0.8t	5.2t	6.5
YA-100	1 t	5.2t	5.2
YA-160	1.6t	8.3t	5.2
YA-320	3.2t	13.4t	4.2
YA-630	6.3t	26.8t	4.3
YA-900	9 t	40.2t	4.5

※Test method of Min. breaking load is
accordance with DIN5684.

※Before surface treatment

※This product must be used
under safety working load.

Stronger hooks and safety latch

Tip-supporting safety latch
brings easy handling.

**Safety latch and
unique hook shape**



**Single action
free spooling**

When loading,
automatically brakes.



ELEPHANT

Specialized manufacturer of highest grade hoist chain

☺ B39 VH, VHC ㊦39 DAT

■ Dimensions

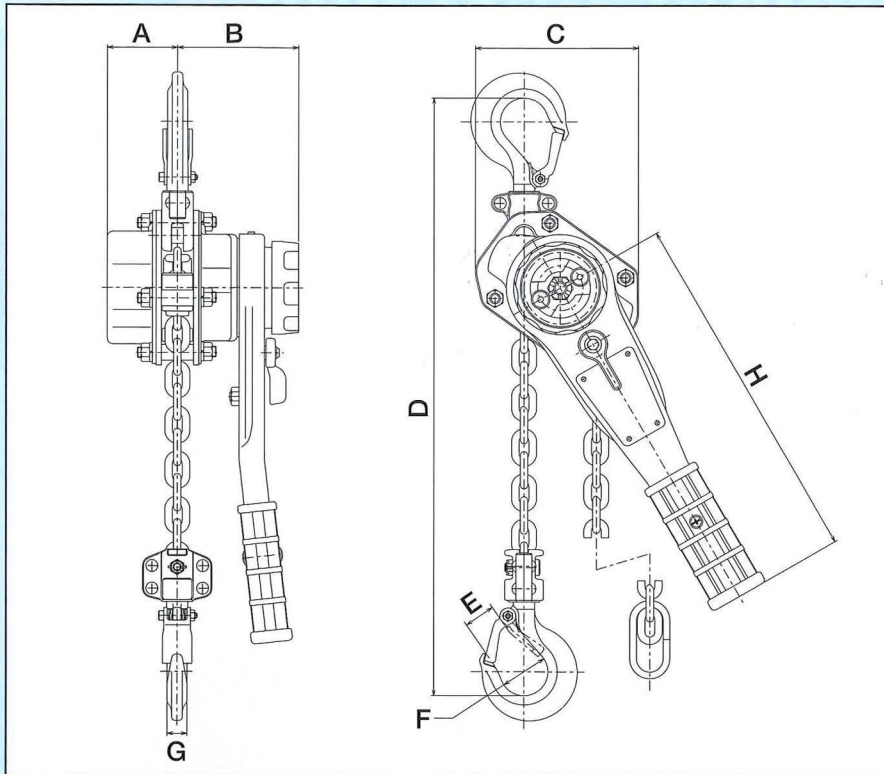

Model	A	B	C	D	E	F	G	H
YA-80	53	91	122	290	23	36	15	268
YA-100	53	91	122	312	28	43	16	268
YA-160	63	99	136	352	29	43	21	310
YA-320	82.5	104	180	420	36	53	28	310
YA-630	82.5	104	235	564	47	70	34	310
YA-900	82.5	104	300	689	73	85	47.5	310

■ Specifications

Model	Safety working load	Standard lift	Hand effort to lift full working load	Diameter of load chain	Net weight
YA-80	0.8 t	1.5m	30kgf	5.6mm	6.0kg
YA-100	1 t	1.5m	37kgf	5.6mm	6.2kg
YA-160	1.6 t	1.5m	30kgf	7.1mm	9.2kg
YA-320	3.2 t	1.5m	37kgf	9mm	15.5kg
YA-630	6.3 t	1.5m	38kgf	9mm×2	26.5kg
YA-900	9 t	1.5m	39kgf	9mm×3	42kg

All specifications herein are subject to change without notice.



F.N. บริษัท เอฟ เอ็น เอ็นจิเนียริง จำกัด
F.N.ENGINEERING CO.,LTD.

Tel: 0-2918-4441-2,0-2918-3378 [Auto] Hotline 08-1174-3345

Fax: 0-2918-3070,0-2918-2722

Email : sale@fnengineering.com , fnengineer@gmail.com

<http://www.fnengineering.co.th>